

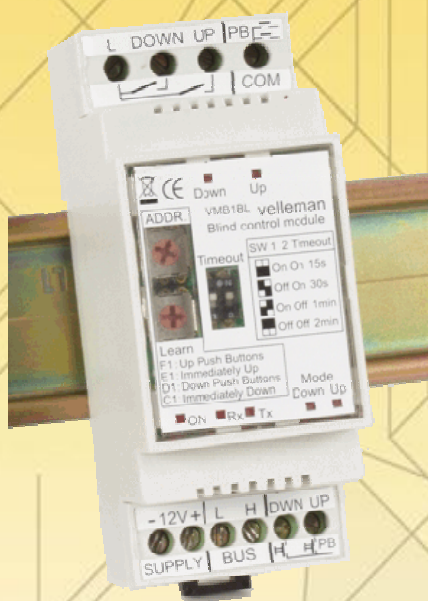

Velleman Home Automation System



VMB1BL

**Blind Control Module
for VELBUS system**

INDEX

Features	3
Velbus data	3
Connection	4
<i>Direct control through several push buttons</i>	4
<i>Control through the VELBUS system</i>	6
<i>Combination of direct push button and VELBUS control</i>	8
<i>Connecting a 24V direct-current motor</i>	9
Use	10
<i>Termination</i>	10
<i>Addressing</i>	11
<i>Switch-off delay</i>	11
<i>Operation</i>	11
<i>LED indication</i>	11
<i>Learning mode</i>	12

Features:

- ◇ Can be used to control an electric roll-down shutter, sunblind...
- ◇ Switching capacity at resistive load: 16A/230VAC max.
- ◇ Switching capacity at inductive load: 8A/230VAC max.
- ◇ Suppressed relay contacts.
- ◇ Manual control on the module.
- ◇ LED indications for:
 - The UP and DOWN relay output
 - The UP and DOWN control modes (fast, very fast or blinking twice and continuously ON)
 - Power voltage
 - Data reception and forwarding through VELBUS
- ◇ 4 possible switching times (adjustable through the 'TIME OUT' toggle switch): 15s - 30s - 1min - 2 min
- ◇ Controllable by connecting several push buttons in parallel.
- ◇ Push button input debounce: 65ms.
- ◇ Controllable through VELBUS.
- ◇ Programmable without PC.
- ◇ Easy learning process by pressing the desired push buttons in the learning mode.
- ◇ Push button commands: up, down, immediately up and immediately down (the up and down commands will be operated through a single push button as from firmware version 0804).
- ◇ Storage space for 14 different push buttons per command group (11 per command group as from firmware version 0804).
- ◇ Learned push buttons will be saved in case of power failure.
- ◇ Reporting towards the control modules in case of LED status modification.
- ◇ 250 possible addresses (adjustable through the 'ADDR' rotating switches)
- ◇ Required mains voltage: 12 ... 18VDC.
- ◇ Consumption in standby: 30mA at 18V (15mA at 16V)
- ◇ Consumption activated relay: 80mA at 18V (60mA at 16VDC)
- ◇ Max. consumption (activated relay and push button input): 95mA at 18V (75mA at 16VDC)
- ◇ Standard DIN rail housing (2 modules)
- ◇ Dimensions (L x W x H): 90 x 36 x 58mm.
- ◇ Weight: 110g

VELBUS:

2-wire communication for the VELBUS data and 2 wires for power.

Data transfer: 16,6Kbit/s.

Serial data protocol: CAN (Controller Area Network)

Short-circuit proof (towards negative or positive of power)

Bus error indication: 2 x short flash of the operation mode LED.

Self restoring after 25 seconds in case of a bus error.

Possibility to assign a name (max. 16 characters) to the UP and DOWN output which can be saved in the non-volatile memory.

The module can react to the push button instructions sent over the VELBUS.

Reporting on the VELBUS in case of a modification of the blind control module.

In case of a modification of the output, the module will send instructions to modify the status of the LEDs on the control modules.

The instructions will be accepted when calling up the module type, the output names, the module status, reading from or writing on the non-volatile memory, the rising, the descending and the stopping of the shutter. The module can respond with the module type, the output names, the module status or the contents from the memory.

CONNECTION

For connection between the modules, use twisted pair cable (ex. EIB 2x2x0.8mm², UTP 8x0.51mm - CAT5 or other). Use minimum 0.5mm² cable. For long wiring (>50m) or if a lot of modules (> 10) are connected to one wire, use 1mm² cable. Connect the 12-18Vdc (mind the polarity) and connect the bus wires (mind the polarity). Connect the roll-down shutter motor according to the drawing below.

The roll-down shutter can be controlled through push buttons which are directly connected to the push button inputs by using the VELBUS or a combination of both.

Direct control through several push buttons:

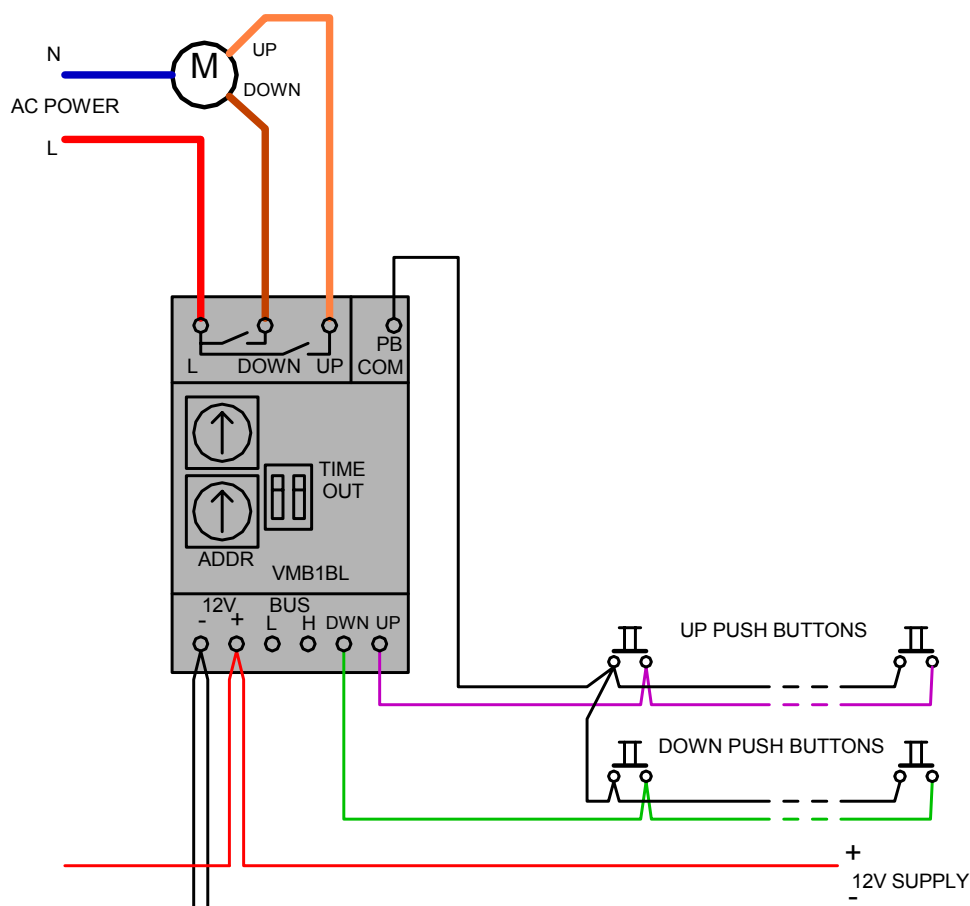

Remark:

To cut the communication with the VELBUS system, enter the address as '00' so as not to report modifications in the status. Clear all learned push buttons (see learning mode) so as not to send any instructions over the VELBUS to control the indication LEDs of the push buttons.

If this is not the case, the blind control module will create a bus error with each status modification.

The up and down commands will be operated through a single push button as from firmware version 0804.

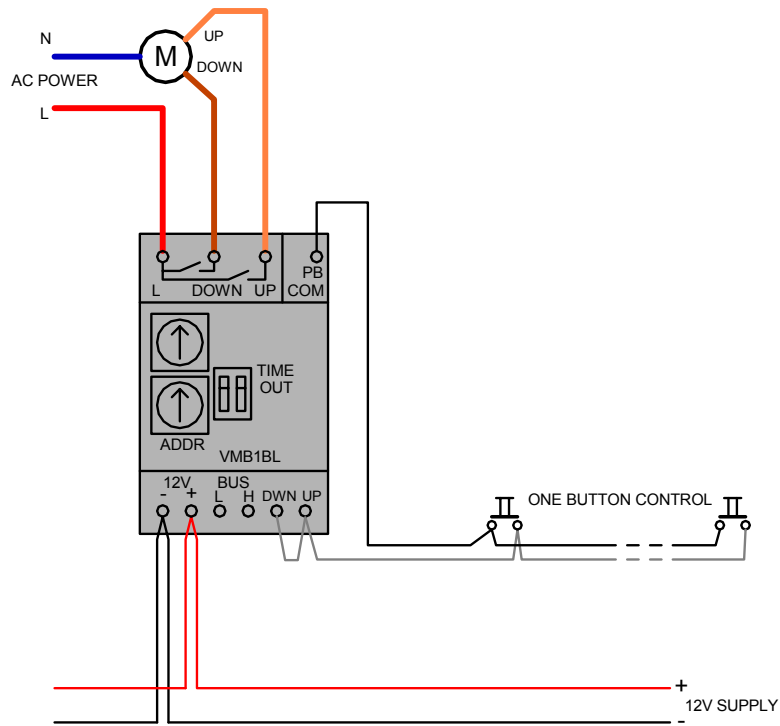

Connection of the up and down commands, and the commands through a single push button is possible by using 2 diodes (1N4007).

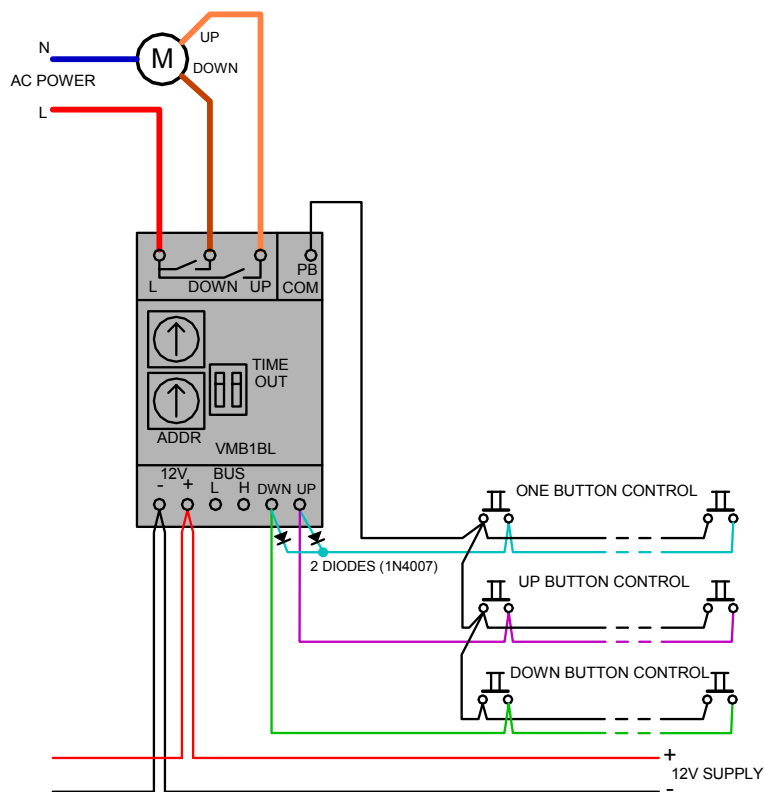

Control through the VELBUS system:

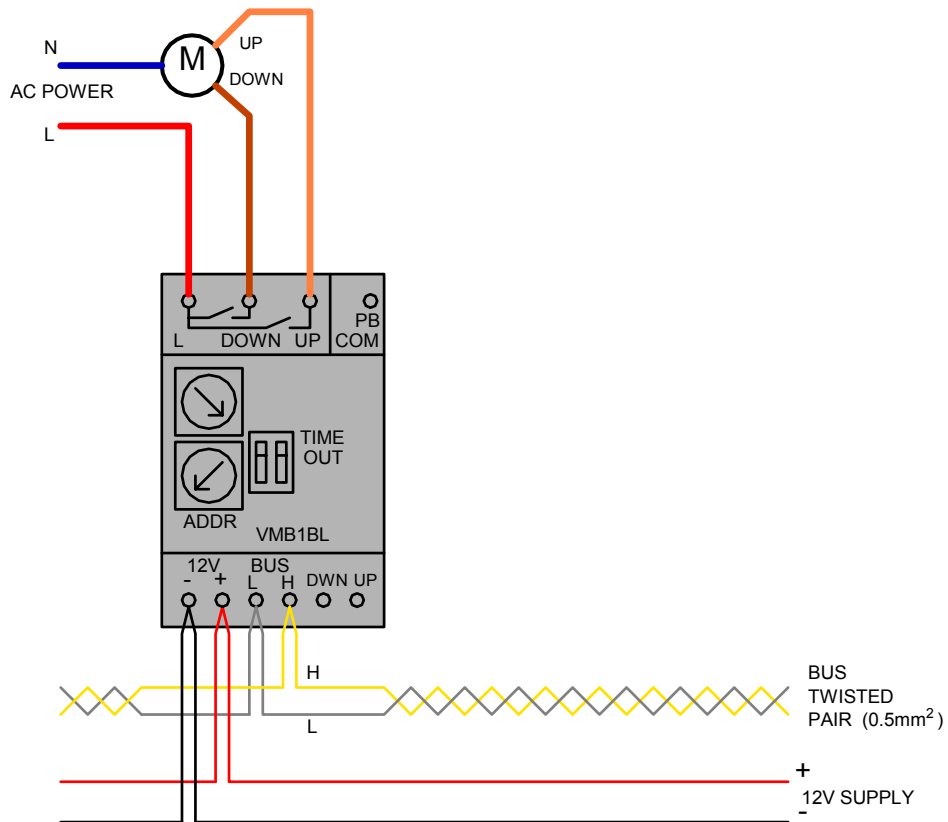

Combination of direct push button and VELBUS control:

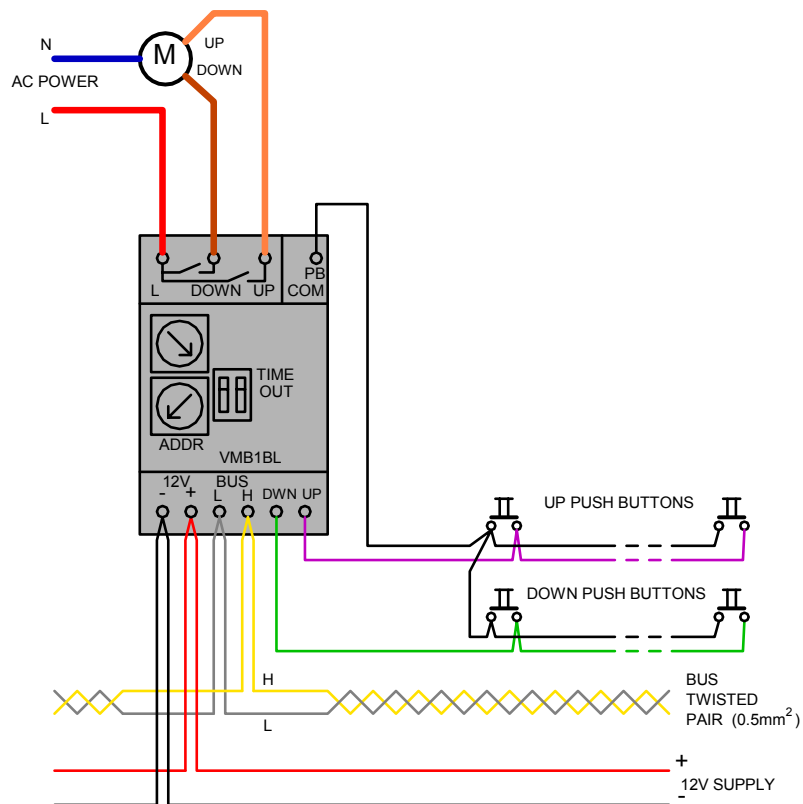

Remark:

Connect the bus (mind the polarity) to the module. Use a twisted pair cable with a 0.5mm² gauge or more with very long connections.

The up and down commands will be operated through a single push button as from firmware version 0804.

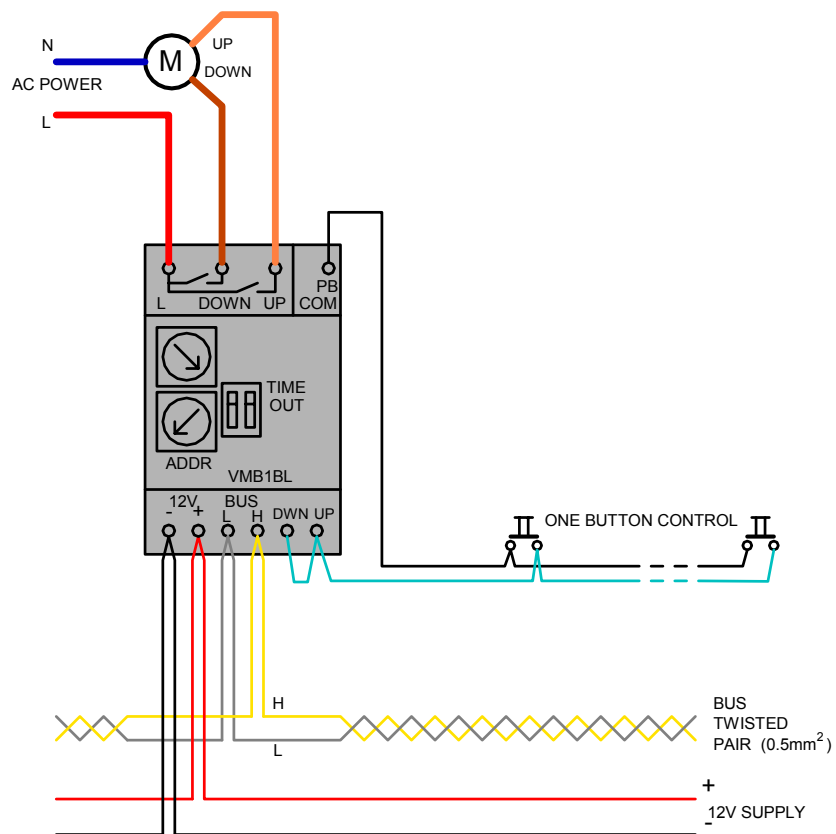

Connection of the up and down commands, and the commands through a single push button is possible by using 2 diodes (1N4007).

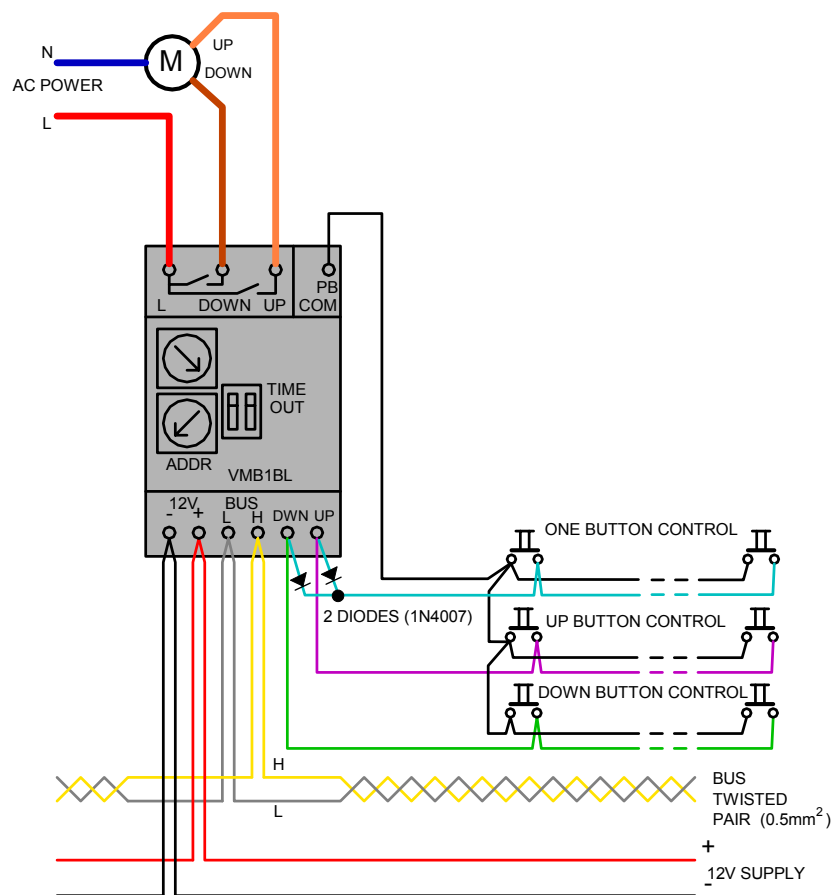

Connecting a 24V direct-current motor

You can connect a 24V direct-current motor by using a transformer with 2 secondary windings and a bridge rectifier.

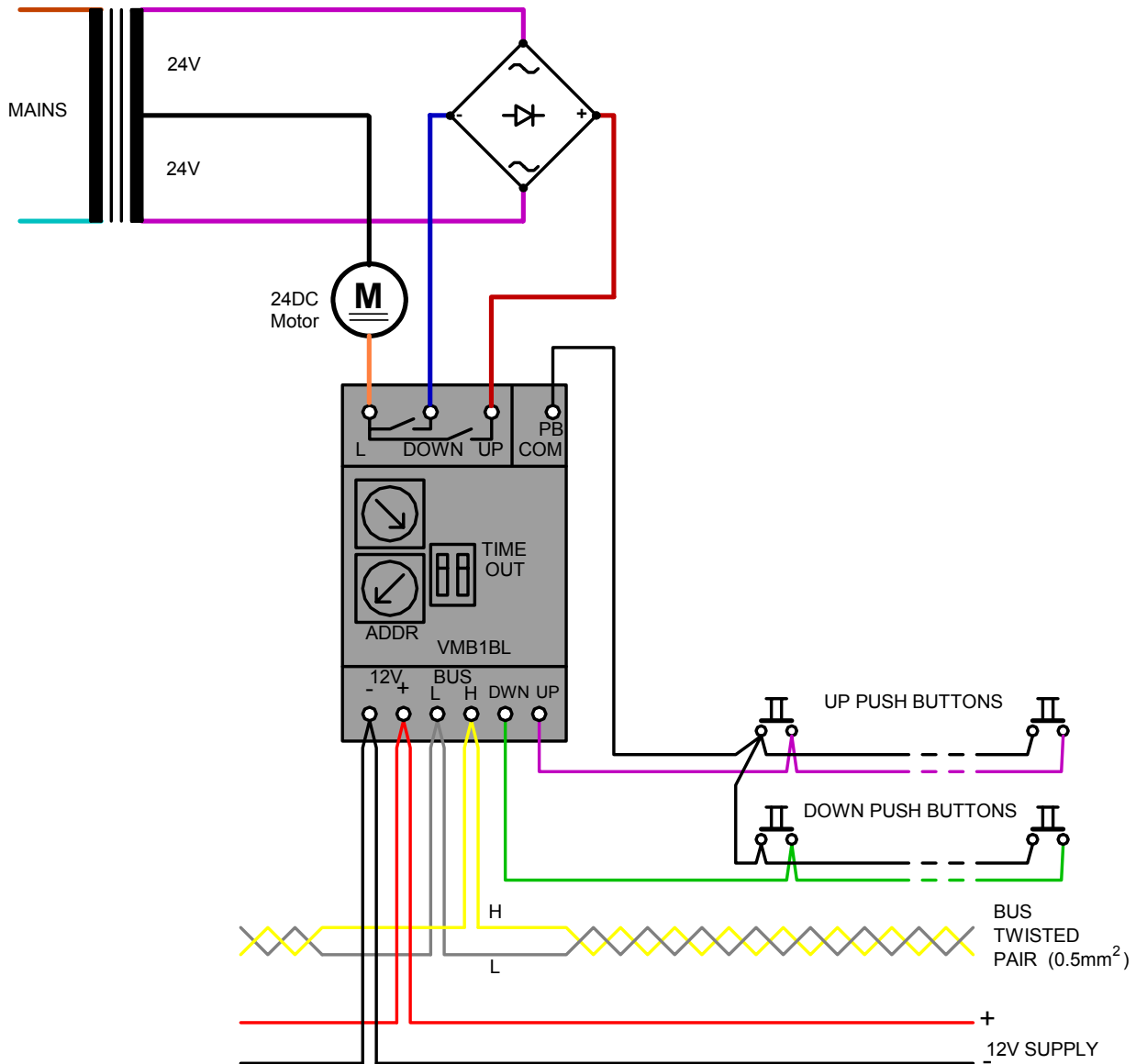

USE:

Remove the lid on the blind control module using a small screwdriver to modify the configuration.

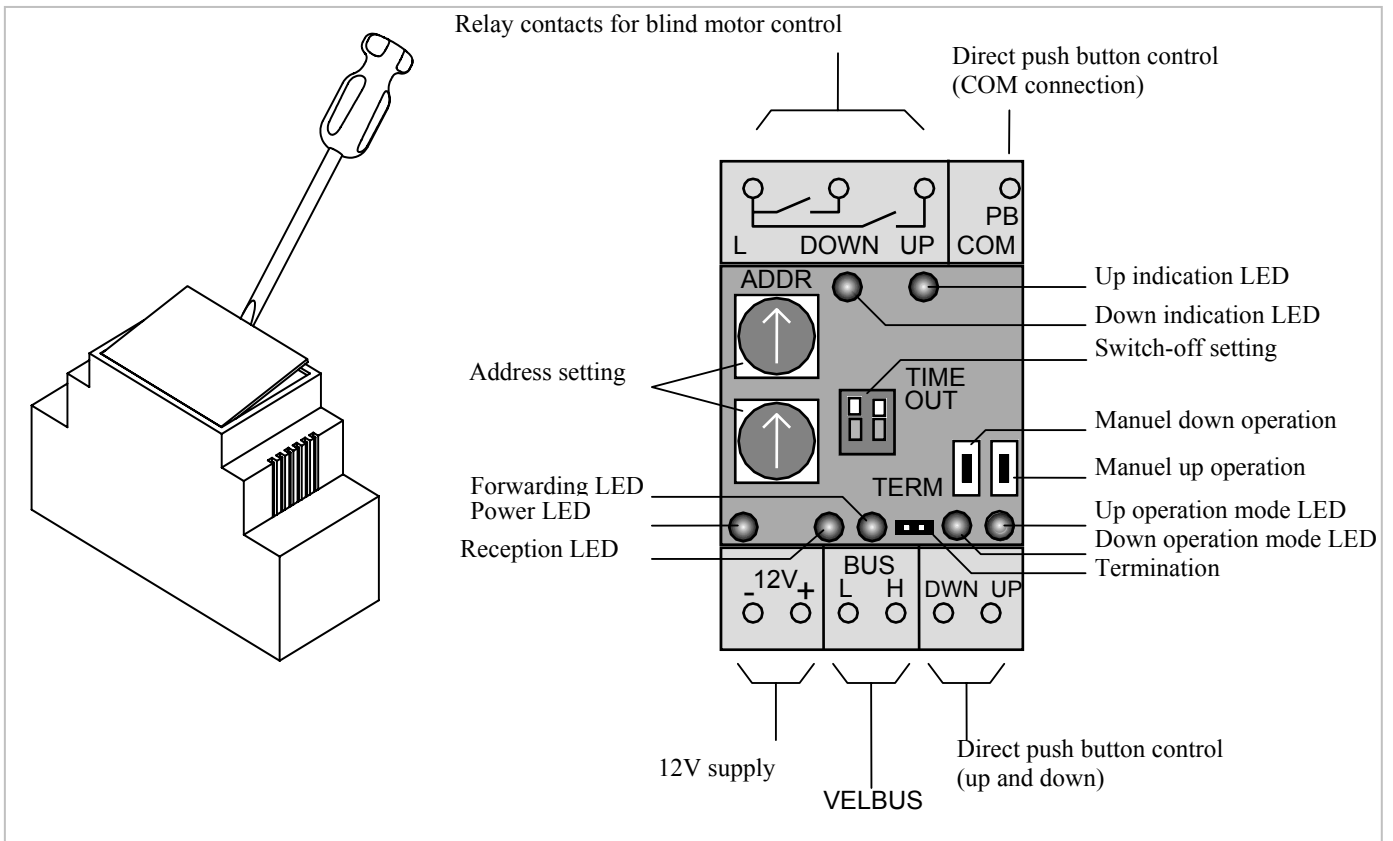

Replace the lid.

Termination:

If the module is connected at the start or end of a cable on the VELBUS, place the 'TERM' jumper.



Remove the jumper in all other cases.



If different cable wiring topologies (tree, star, loop, ...) are used, place a jumper on the end module of the longest cable only, NOT on each end point.

Addressing:

Enter a unique address (from '00' to 'FE' except for 'B1', 'C1', 'D1', 'E1', 'F1' and 'FF') for each module through the 'ADDR' rotating switches. These addresses can be used to learn the push buttons.

In case of a modification of the addresses, the UP and DOWN outputs will be disabled and all LEDs of the corresponding push buttons will be turned out.

Switch-off delay:

The complete rise or descent of the roll-down shutter (or blind) takes some time. The output of the blind control module has to be activated during min. this period of time. To avoid surcharging the engine, the output of the module will shut off after a period depending on the setup of the bipolar toggle switch.:

TIME OUT switch 1	TIME OUT switch2	Switch-off delay
On	On	15s
Off	On	30s
On	Off	1min
Off	Off	2min

Enter a time which is just a little longer than the time needed for the shutter to rise or descend completely

Operation:

- A short press on the UP or DOWN push button will rise or descend the roll-down shutter. After the set switch-off delay the module will switch off automatically.
- Stop the shutter at any time by pressing a push button of the opposite direction.
- Maintaining the UP or DOWN push button pressed will move the shutter until the push button is released or the switch-off delay has expired.
- Pressing the UP and DOWN push buttons simultaneously will switch off the shutter motor.
- Pressing the IMMEDIATE UP push button will rise the shutter completely even if it was descending.
- Pressing the IMMEDIATE DOWN push button will descend the shutter completely even if it was rising.
- The up and down commands will be operated through a single push button as from firmware version 0804. Operate this push button to move the blind, operate again to stop the blind, operate again to move the blind in the opposite direction. Press and hold the push button and release to stop the blind motor.

LED indication:

The LEDs of the control modules and the operation LEDs on the blind control module will indicate the status:

- The power LEDs do not light up if the DOWN and UP outputs are switched off.
- The DOWN power LED blinks if the DOWN output is switched on and the switch-off delay has started.
- The DOWN power LED lights if the DOWN output is switched on and the switch-off delay is not activated.
- The UP power LED blinks if the UP output is deactivated and the switch-off delay has started.
- The UP power LED lights if the UP output is activated and the switch-off delay is not activated.

Learning Mode:

Only push buttons connected to the Velbus via a push button interface or a control panel are appropriate for the procedure below.

Following push buttons can be learned: up, immediate up, down and immediate down. Each command can accept up to 14 different push buttons.

As from firmware version 0804 you will also be able to learn push buttons which will raise and lower the blind. The number of push buttons per command group has been narrowed down to 11.

Memorize the unique address of the module.

Enter the address of the module as follows:

Address	Command
F1	Learning push buttons rising the shutter
E1	Learning push buttons rising the shutter immediately and completely
D1	Learning push buttons lowering the shutter
C1	Learning push buttons lowering the shutter immediately and completely
B1	Learning push buttons raising and lowering the blind (as from firmware version 0804)

The outputs will be deactivated and the UP or DOWN operation LED will blink rapidly to indicate the learning mode. The LEDs of the learned push buttons will blink rapidly as well. You can easily detect which push buttons have been learned for the UP or DOWN control.

Add a specific push button by maintaining it pressed until the output activates. Releasing the push button will deactivate the output while the indication LED of the push button blinks rapidly as confirmation. You can not add any more push buttons when the maximum number of push buttons has been reached.

A learned push button can be deleted by maintaining it pressed. Releasing it will turn off the indication LED of the push button.

Delete all learned push buttons of a control group by maintaining pressed the manual control on the blind control module until the output switches on. Releasing the manual control push button will deactivate the output and turn off the indication LEDs of each corresponding push button.

Repeat the procedure above to learn other commands to the push buttons.

Exit the learning mode by resetting the address of the blind control module at the original value.

When using firmware version 0735 you will be able to delete all push buttons saved into the memory of the blind control module at once. Set the address to one of the learning addresses. Maintain the manual control on the blind control module pressed for 10 seconds. The relay will activate and deactivate again after 7 seconds to confirm the push buttons have been erased. Set the address back to its original value.

Velleman Home Automation System

Velleman[®] is a major distributor of electronic products and components and has its own R & D department. Velleman[®] is market leader in electronic kits with offices all over the world.



In-house training & demonstration facility.

