

# TWIN-MOTOR GEARBOX KIT

- ◆ Two motor and gear sets to have wheels running in different direction.
- ◆ 3 kinds gear ratio and output for your choice.
- ◆ Wheels, tires and all other necessary parts included.
- ◆ Easy to follow instruction manual included.

## Tools You May Need



+ Screwdriver



Pliers



Side Cutter

## Gear Ratio

**A** 1:60

/200

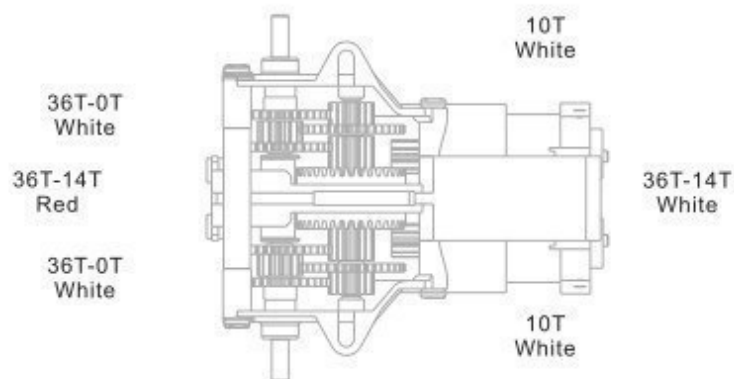

## MODE D'EMPLOI

## KIT BOÎTE DE VITESSES À 2 MOTEURS

- 2 moteurs et 3 jeux de pignons font tourner les roues dans différentes directions
- 3 rapports de démultiplication
- roues, pneus et toutes les pièces nécessaires inclus

## Outils nécessaires

- + tournevis
- pince
- pince coupante diagonale

## Rapport de démultiplication

**B** 1:120 Gear ratio / 100 RPM output

rapport de démultiplication 1:120 / 100 tpm

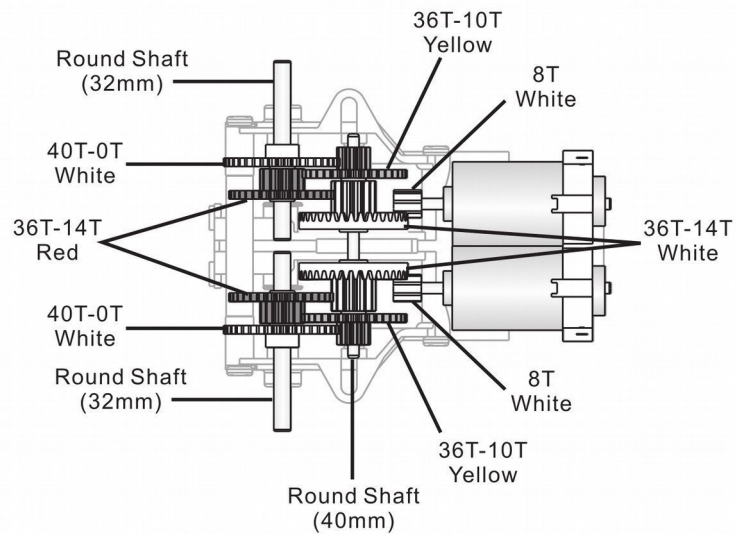

**C** 1:288 Gear ratio / 42 RPM output

rapport de démultiplication 1:288 / 42 tpm

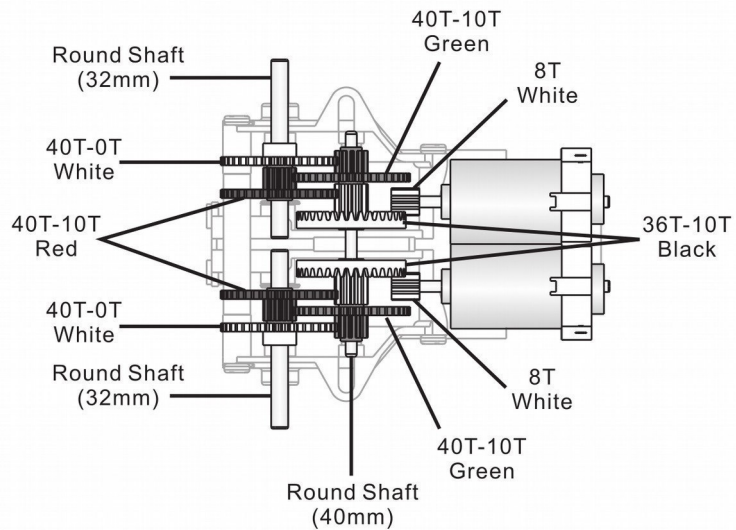

## Plastic Part

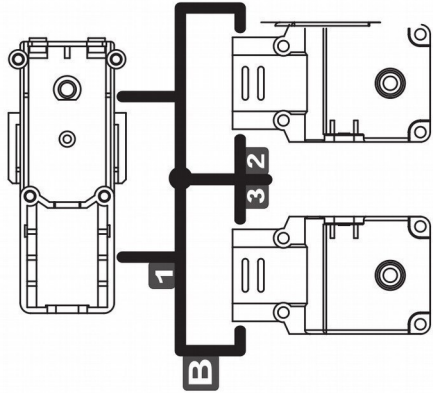

## Pièces en plastique

## Gear Box Assembly

STEP  
1





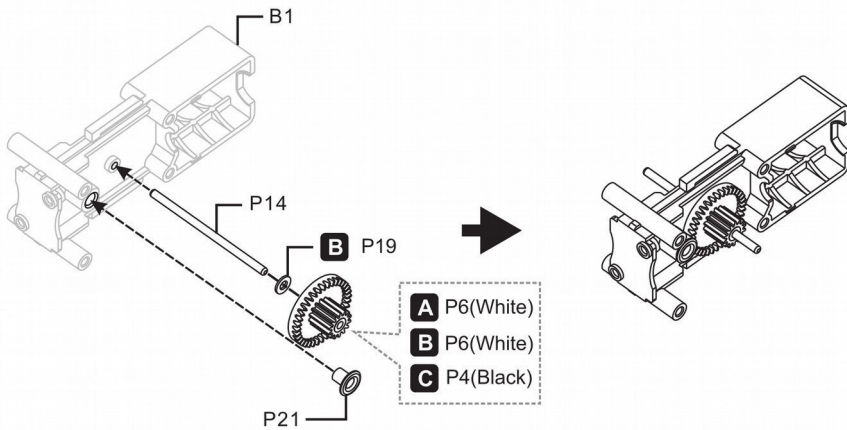





















A 1:60 B 1:120 C 1:288



## Montage de la boîte de vitesses

## Mechanical Parts List

<b>P1</b>	<b>Motor</b>	Qty		<b>P2</b>	<b>Gear 8T</b>	Qty		<b>P3</b>	<b>Gear 10T</b>	Qty		<b>P4</b>	<b>Gear 36T/10T</b>	Qty	
		2			 White (small)	2			 White (big)	2			 Black	2	
<b>P5</b>	<b>Gear 36T/10T</b>	Qty		<b>P6</b>	<b>Gear 36T/14T</b>	Qty		<b>P7</b>	<b>Gear 36T/14T</b>	Qty		<b>P8</b>	<b>Gear 40T/10T</b>	Qty	
	 Yellow	2			 White	2			 Red (small)	2			 Red (big)	2	
<b>P9</b>	<b>Gear 36T/14T</b>	Qty		<b>P10</b>	<b>Gear 40T/10T</b>	Qty		<b>P11</b>	<b>Gear 36T/0T</b>	Qty		<b>P12</b>	<b>Gear 40T/0T</b>	Qty	
	 Green (small)	2			 Green (big)	2			 White (small)	2			 White (big)	2	
<b>P13</b>	<b>Nylon Connector</b>	Qty		<b>P14</b>	<b>Round Shaft</b>	Qty		<b>P15</b>	<b>Tapping Screw</b>	Qty		<b>P16</b>	<b>Machine Screw</b>	Qty	
		2			 40mm	1				8 (2.6x14)				2 (2.6x10)	
<b>P17</b>	<b>Tapping Screw</b>	Qty		<b>P18</b>	<b>Tapping Screw</b>	Qty		<b>P19</b>	<b>Washer</b>	Qty		<b>P20</b>	<b>Nut</b>	Qty	
		2 (2.6x6)				2 (2.6x6)				2				2	
<b>P21</b>	<b>Eyelet</b>	Qty		<b>P22</b>	<b>Round Spacer</b>	Qty		<b>P23</b>	<b>Wheel</b>	Qty		<b>P24</b>	<b>Tire</b>	Qty	
		4				2				2				2	

## Liste des pièces mécaniques

**STEP 2**



**A 1:60 B 1:120 C 1:288**

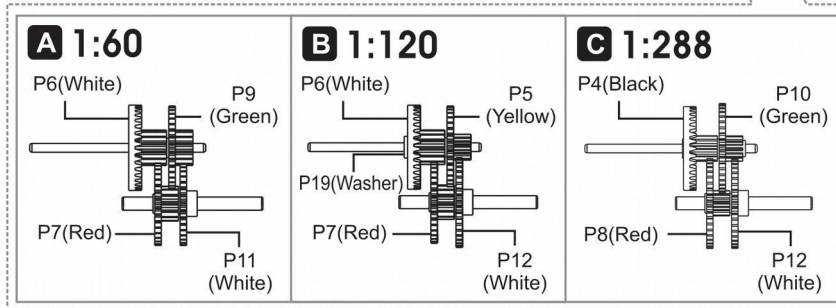
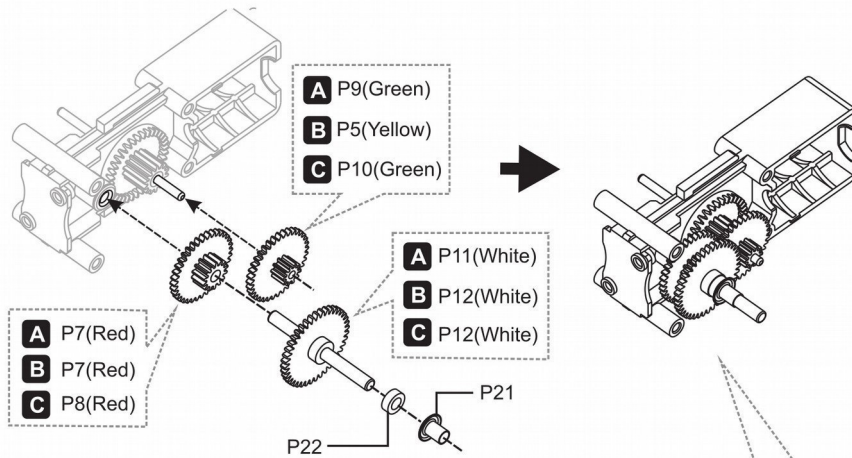

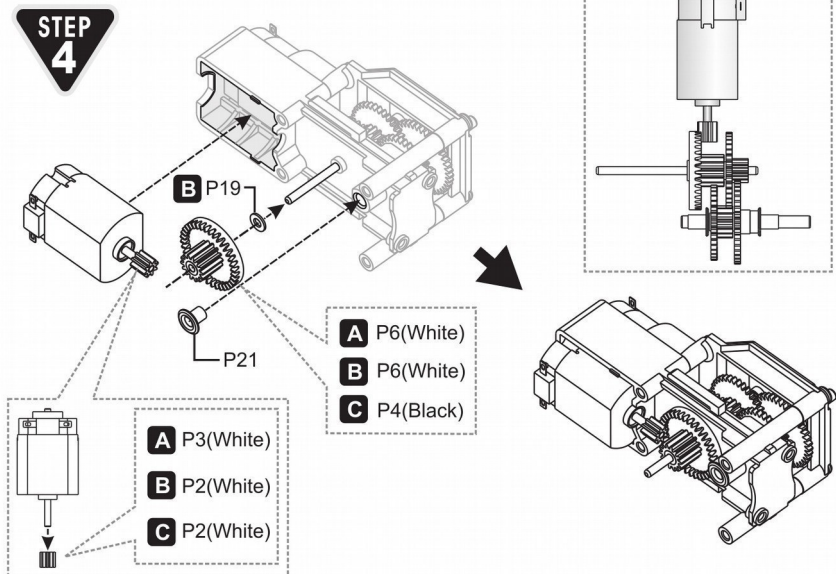
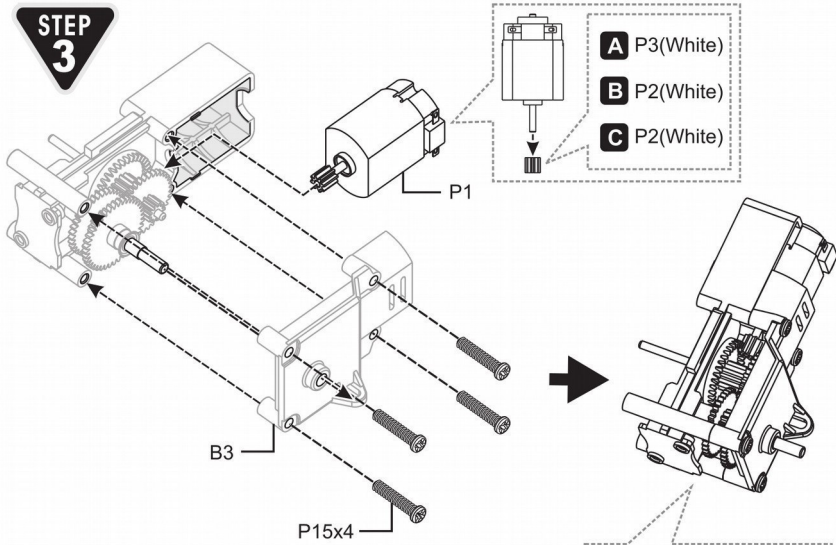

**STEP 5**

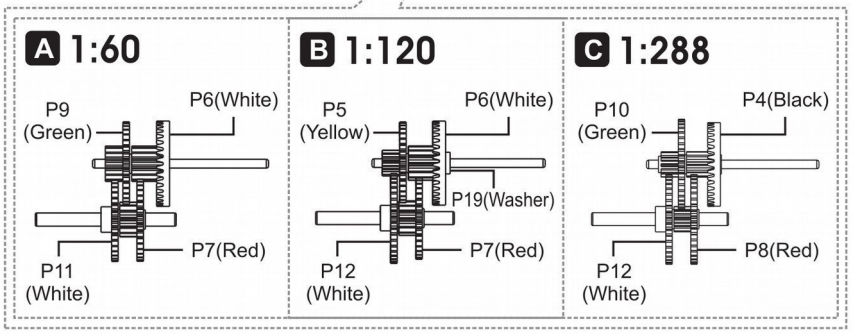
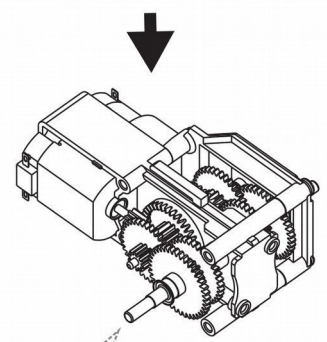
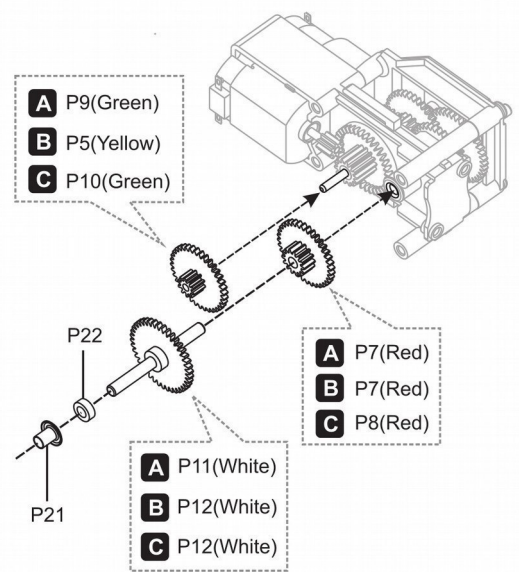

**STEP  
6**

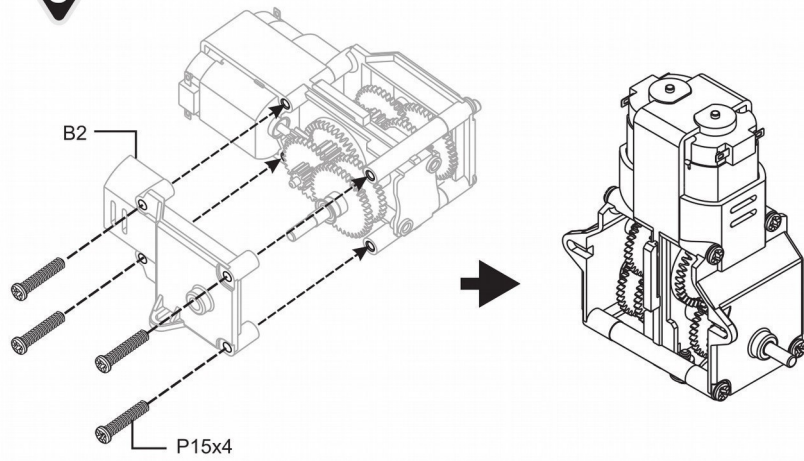

## Application

**1**

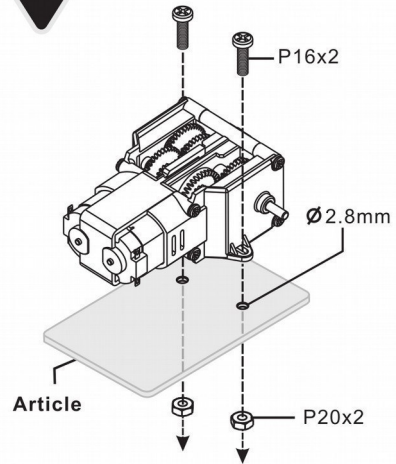

**2**

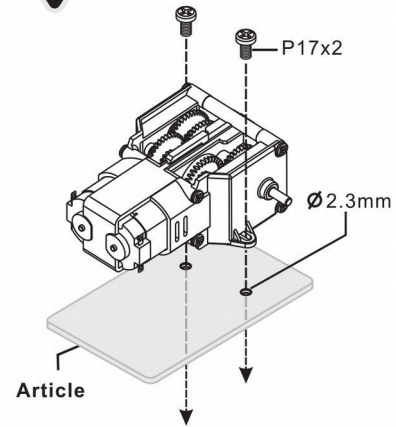

3

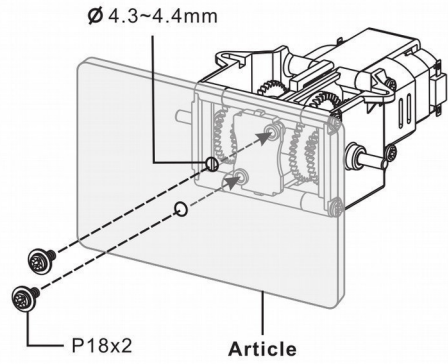

4

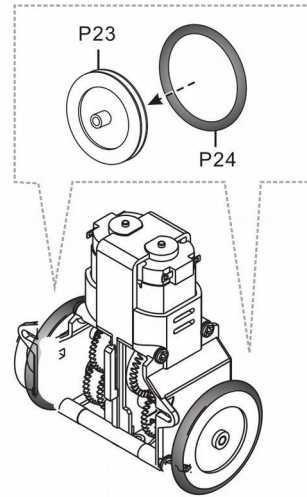

5-1

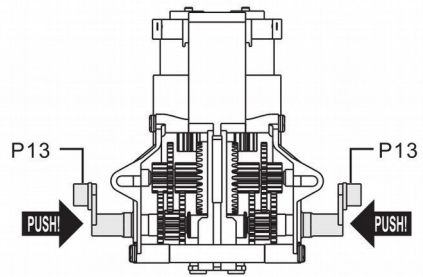

5-2

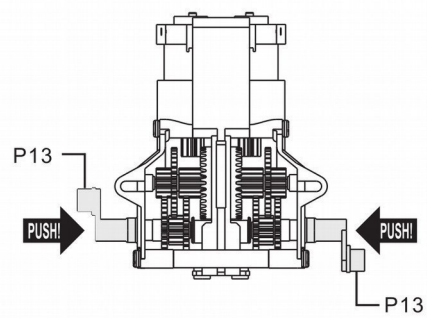

N'employer cet appareil qu'avec des accessoires d'origine. La SA Velleman ne peut, dans la mesure conforme au droit applicable être tenue responsable des dommages ou lésions (directs ou indirects) pouvant résulter de l'utilisation de cet appareil.

Pour plus d'informations concernant cet article et la dernière version de ce mode d'emploi, consulter notre site [www.velleman.eu](http://www.velleman.eu).

Toutes les informations présentées dans cette notice peuvent être modifiées sans notification préalable.

#### © DROITS D'AUTEUR

SA Velleman est l'ayant droit des droits d'auteur de ce mode d'emploi. Tous droits mondiaux réservés. Toute reproduction, traduction, copie ou diffusion, intégrale ou partielle, du contenu de cette notice par quelque procédé ou sur tout support électronique que ce soit est interdite sans l'accord préalable écrit de l'ayant droit.



Aux résidents de l'Union européenne  
Informations environnementales importantes concernant ce produit

Ce symbole sur l'appareil ou l'emballage indique que l'élimination d'un appareil en fin de vie peut polluer l'environnement. Ne pas jeter un appareil électrique ou électronique (et des piles éventuelles) parmi les déchets municipaux non sujets au tri sélectif ; une déchetterie traitera l'appareil en question.

Renvoyer cet appareil à votre fournisseur ou à un service de recyclage local. Il convient de respecter la réglementation locale relative à la protection de l'environnement.

En cas de questions, contacter les autorités locales pour élimination.

Nous vous remercions de votre achat ! Lire le présent mode d'emploi attentivement avant la mise en service de l'appareil. Si l'appareil a été endommagé pendant le transport, ne pas l'installer et consulter votre revendeur.