

TWIN-MOTOR GEARBOX KIT

- ◆ Two motor and gear sets to have wheels running in different direction.
- ◆ 3 kinds gear ratio and output for your choice.
- ◆ Wheels, tires and all other necessary parts included.
- ◆ Easy to follow instruction manual included.

Tools You May Need



+ Screwdriver

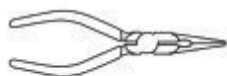

Pliers



Side Cutter

Gear Ratio

A 1:60

/200

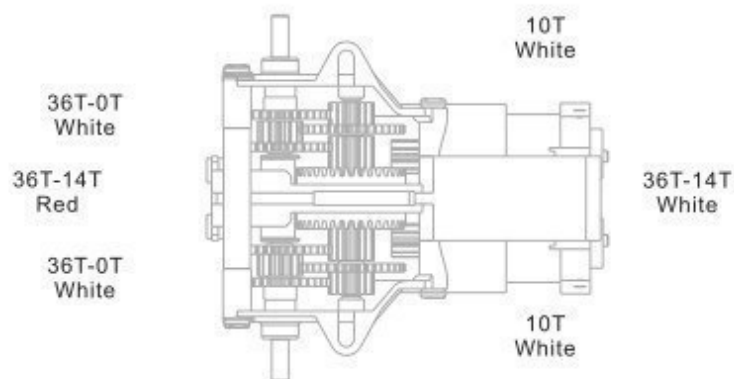

MANUAL DEL USUARIO

JUEGO DE CAJA DE ENGRANAJES Y 2 MOTORES

- 2 motores y 3 juegos de ruedas dentadas hacen girar las ruedas en diferentes direcciones
- 3 relaciones de transmisión
- ruedas, neumáticos y todas las piezas necesarias incl.

Herramientas necesarias

- + destornillador
- alicates
- alicates de corte en diagonal

Relación de transmisión

B 1:120 Gear ratio / 100 RPM output

relación de transmisión 1:120 / 100 rpm

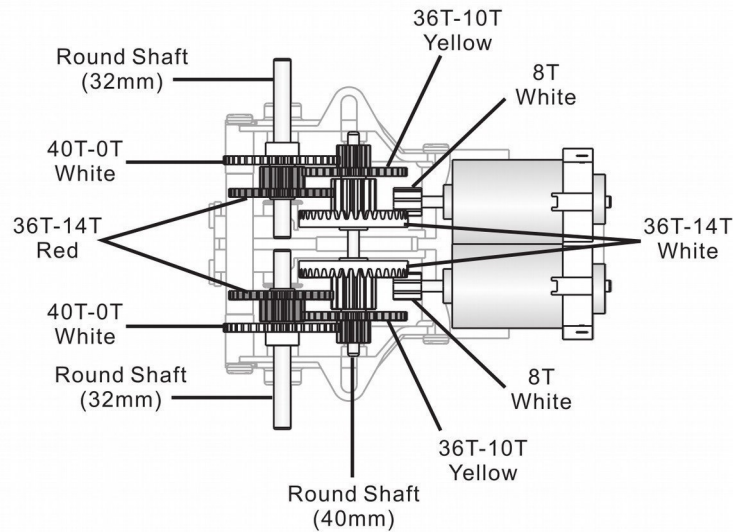

C 1:288 Gear ratio / 42 RPM output

relación de transmisión 1:288 / 42 rpm

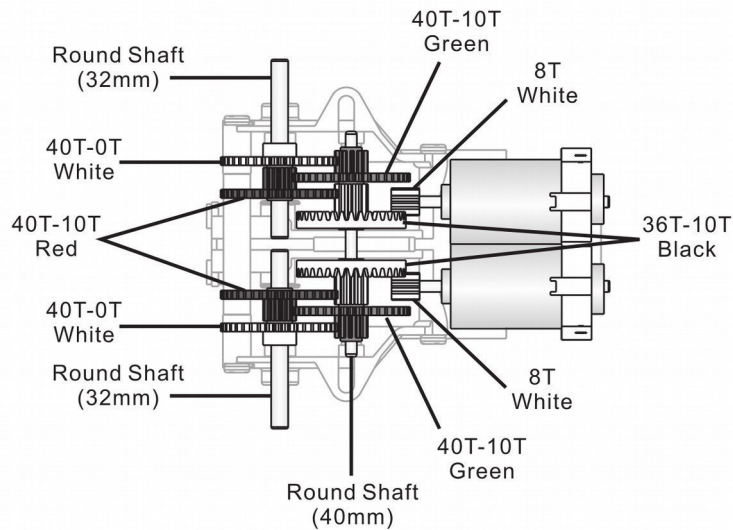

Plastic Part

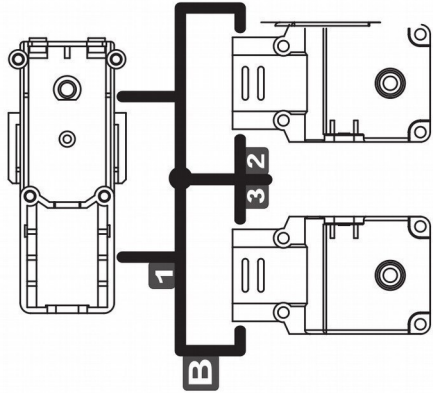

Pieza de plástico

Gear Box Assembly

STEP
1





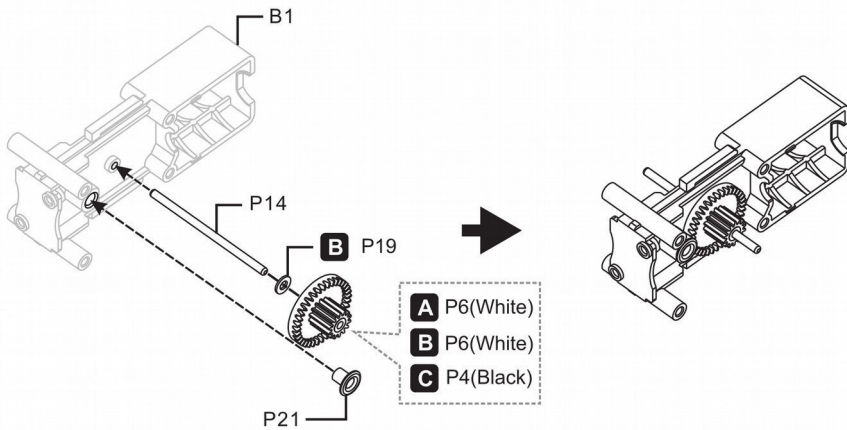





















A 1:60 **B** 1:120 **C** 1:288



Montar la caja de engranaje

Mechanical Parts List

P1	Motor	Qty		P2	Gear 8T	Qty		P3	Gear 10T	Qty		P4	Gear 36T/10T	Qty	
		2			 White (small)	2			 White (big)	2			 Black	2	
P5	Gear 36T/10T	Qty		P6	Gear 36T/14T	Qty		P7	Gear 36T/14T	Qty		P8	Gear 40T/10T	Qty	
	 Yellow	2			 White	2			 Red (small)	2			 Red (big)	2	
P9	Gear 36T/14T	Qty		P10	Gear 40T/10T	Qty		P11	Gear 36T/0T	Qty		P12	Gear 40T/0T	Qty	
	 Green (small)	2			 Green (big)	2			 White (small)	2			 White (big)	2	
P13	Nylon Connector	Qty		P14	Round Shaft	Qty		P15	Tapping Screw	Qty		P16	Machine Screw	Qty	
		2			 40mm	1				8 (2.6x14)				2 (2.6x10)	
P17	Tapping Screw	Qty		P18	Tapping Screw	Qty		P19	Washer	Qty		P20	Nut	Qty	
		2 (2.6x6)				2 (2.6x6)				2				2	
P21	Eyelet	Qty		P22	Round Spacer	Qty		P23	Wheel	Qty		P24	Tire	Qty	
		4				2				2				2	

Lista de componentes mecánicos

**STEP
2**



A 1:60 B 1:120 C 1:288

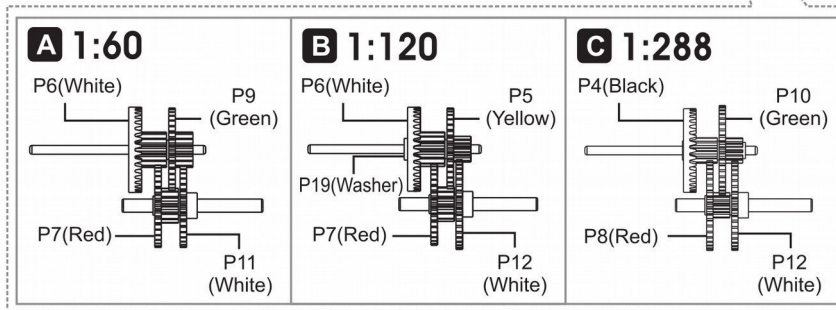
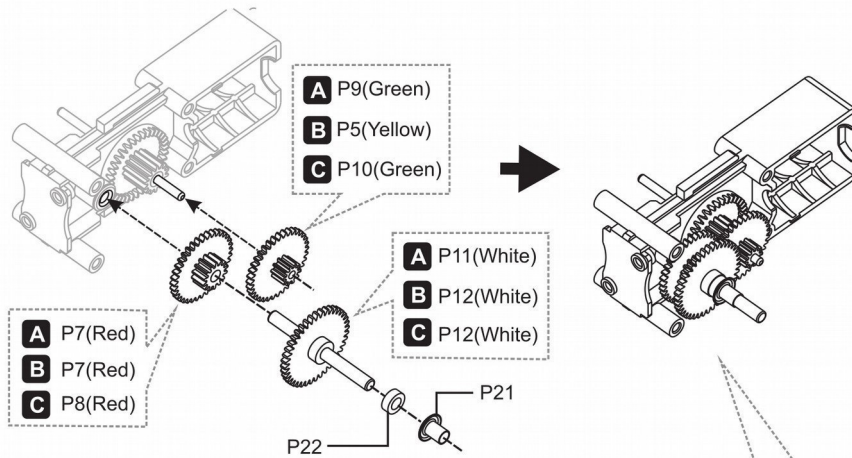

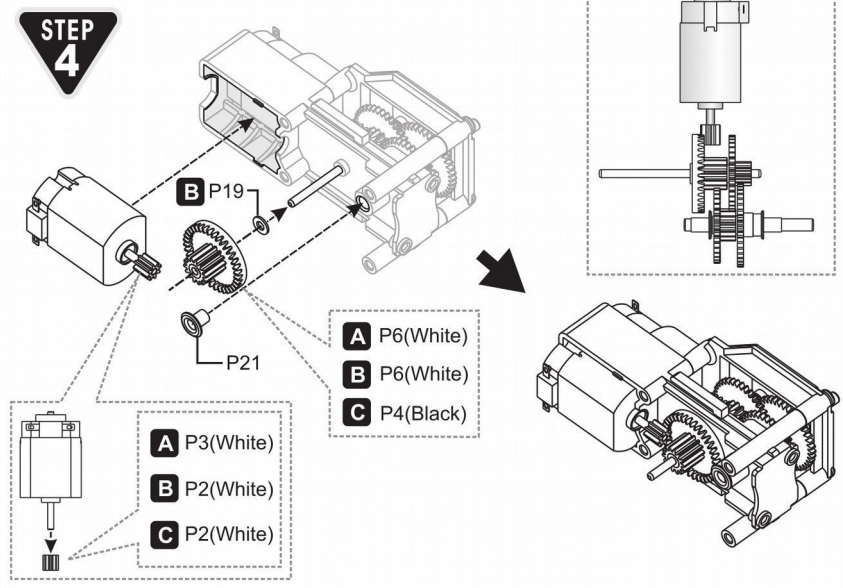
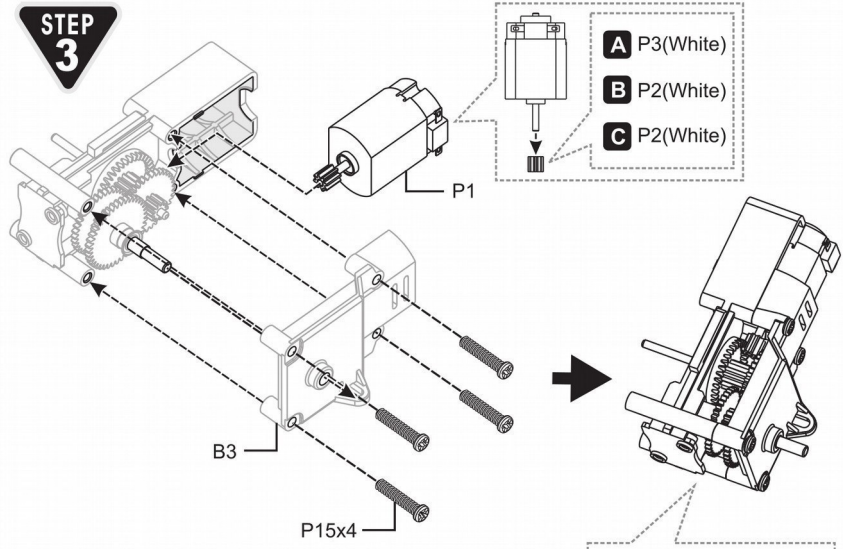

STEP 5

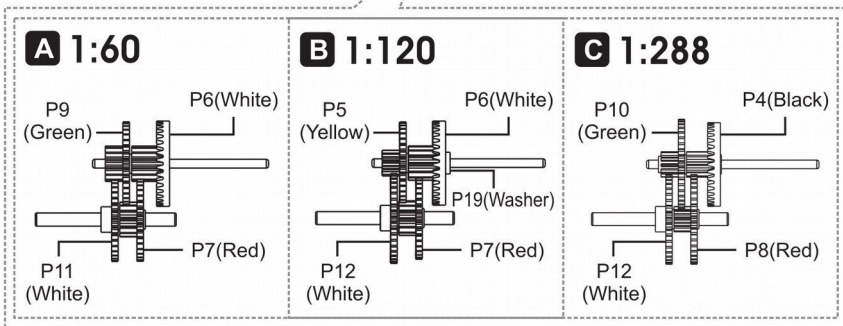
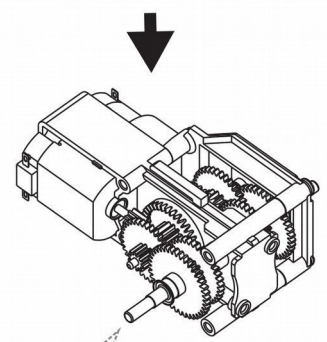
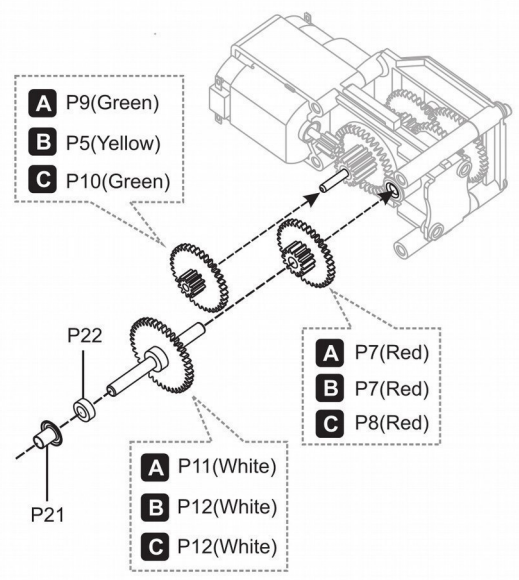

**STEP
6**

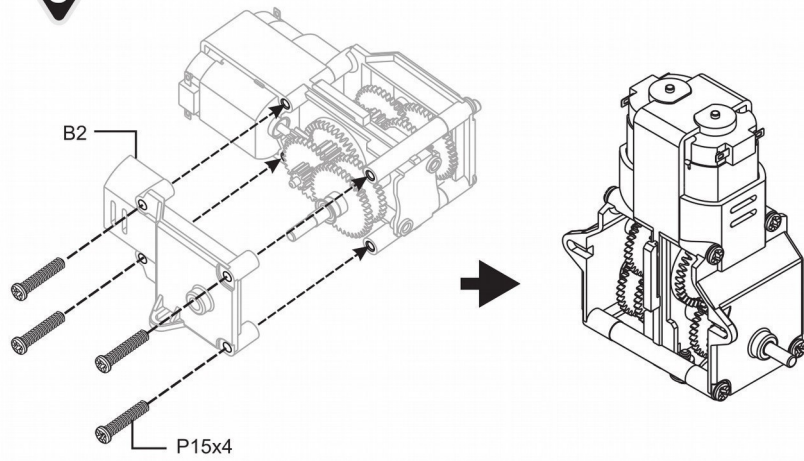

Application

1

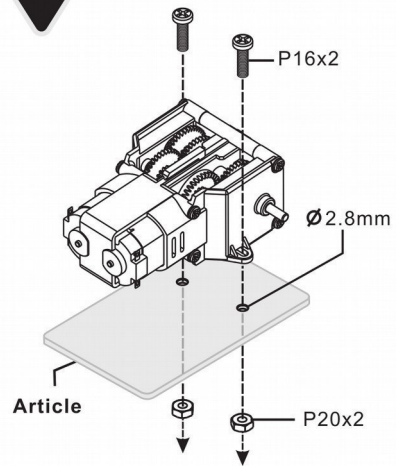

2

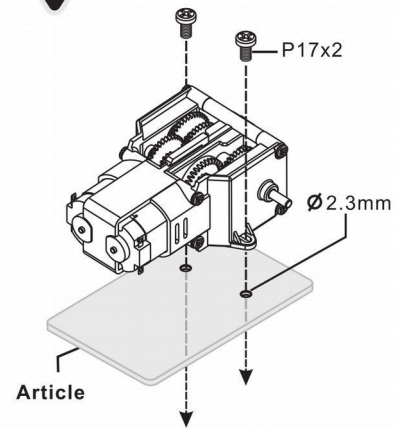

3

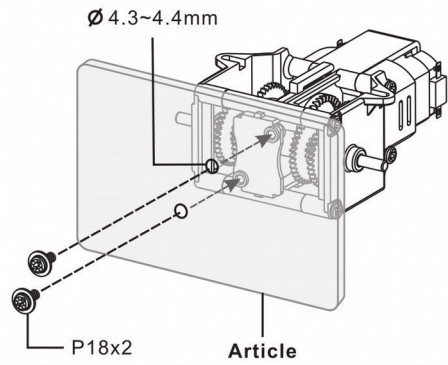

4

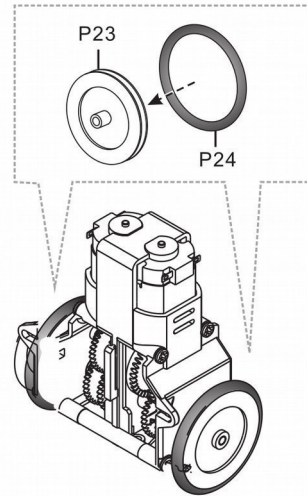

5-1

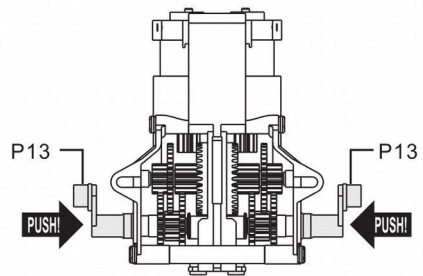

5-2

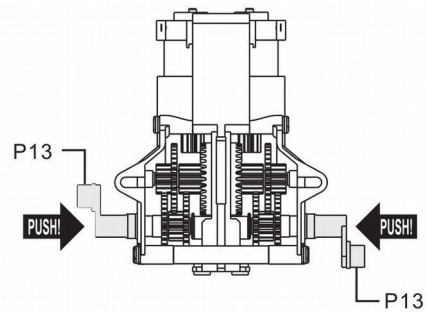

Utilice este aparato sólo con los accesorios originales. Velleman NV no será responsable de daños ni lesiones causados por un uso (indebido) de este aparato.

Para más información sobre este producto y la versión más reciente de este manual del usuario, visite nuestra página www.velleman.eu.

Se pueden modificar las especificaciones y el contenido de este manual sin previo aviso.

© DERECHOS DE AUTOR

Velleman NV dispone de los derechos de autor para este manual del usuario. Todos los derechos mundiales reservados. Está estrictamente prohibido reproducir, traducir, copiar, editar y guardar este manual del usuario o partes de ello sin el consentimiento previo por escrito del propietario del copyright.



A los ciudadanos de la Unión Europea
Importantes informaciones sobre el medio ambiente
concerniente a este producto
Este símbolo en este aparato o el embalaje indica que, si
tira las muestras inservibles, podrían dañar el medio
ambiente. No tire este aparato (ni las pilas, si las
hubiera) en la basura doméstica; debe ir a una empresa
especializada en reciclaje.

Devuelva este aparato a su distribuidor o a la unidad de reciclaje local.

Respete las leyes locales en relación con el medio ambiente.

Si tiene dudas, contacte con las autoridades locales para residuos.

¡Gracias por elegir Velleman! Lea atentamente las instrucciones del manual antes de usar el aparato. Si ha sufrido algún daño en el transporte no lo instale y póngase en contacto con su distribuidor.