

Total solder points: 94

Difficulty level: beginner 1  2  3  4  5  advanced

## CAR HEADLIGHT ALARM

# K3505

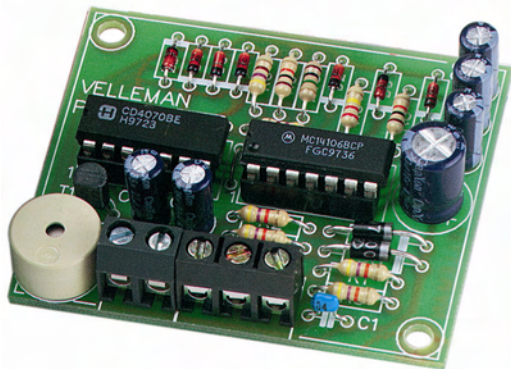

No more dead batteries due to  
headlights that were left on.



**VELLEMAN NV**

**Legen Heirweg 33**

**9890 Gavere**

**Belgium Europe**

**[www.velleman.be](http://www.velleman.be)**

**[www.velleman-kit.com](http://www.velleman-kit.com)**

**Features:**

- ☑ Continuously repeated alarm tone for lights ON (may be disabled)
- ☑ Repeated alarm tone for lights OUT
- ☑ Only 3 wires are required for hook-up

**Specifications:**

- Supply voltage: 12V battery
- PCB dimensions: 48 x 57mm (1.9" x 2.2")
- Recommended housing: WCAH2855

### 1. Assembly (Skipping this can lead to troubles !)

Ok, so we have your attention. These hints will help you to make this project successful. Read them carefully.

#### 1.1 Make sure you have the right tools:

- A good quality soldering iron (25-40W) with a small tip.
- Wipe it often on a wet sponge or cloth, to keep it clean; then apply solder to the tip, to give it a wet look. This is called 'thinning' and will protect the tip, and enables you to make good connections. When solder rolls off the tip, it needs cleaning.
- Thin raisin-core solder. Do not use any flux or grease.
- A diagonal cutter to trim excess wires. To avoid injury when cutting excess leads, hold the lead so they cannot fly towards the eyes.
- Needle nose pliers, for bending leads, or to hold components in place.
- Small blade and Phillips screwdrivers. A basic range is fine.

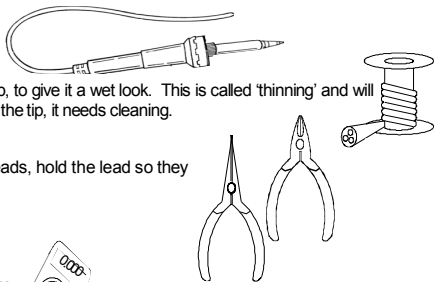

**For some projects, a basic multi-meter is required, or might be handy**

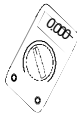

#### 1.2 Assembly Hints :

- ⇒ Make sure the skill level matches your experience, to avoid disappointments.
  - ⇒ Follow the instructions carefully. Read and understand the entire step before you perform each operation.
  - ⇒ Perform the assembly in the correct order as stated in this manual
  - ⇒ Position all parts on the PCB (Printed Circuit Board) as shown on the drawings.
  - ⇒ Values on the circuit diagram are subject to changes.
  - ⇒ Values in this assembly guide are correct\*
  - ⇒ Use the check-boxes to mark your progress.
  - ⇒ Please read the included information on safety and customer service
- \* Typographical inaccuracies excluded. Always look for possible last minute manual updates, indicated as 'NOTE' on a separate leaflet.

### 1.3 Soldering Hints :

1- Mount the component against the PCB surface and carefully solder the leads

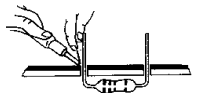

2- Make sure the solder joints are cone-shaped and shiny

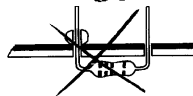
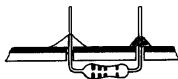

3- Trim excess leads as close as possible to the solder joint

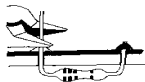

REMOVE THEM FROM THE TAPE ONE AT A TIME !

**DO NOT BLINDLY FOLLOW THE ORDER OF THE COMPONENTS ON THE TAPE. ALWAYS CHECK THEIR VALUE ON THE PARTS LIST!**

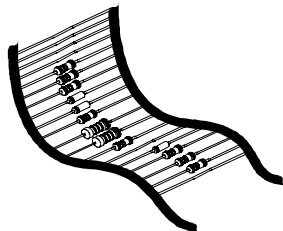

**1. Jumper**

- Between IC1 & IC2

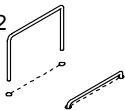
**2. Diodes. Watch the polarity !**

- D1 : 1N4148  
 D2 : 1N4148  
 D3 : 1N4148  
 D4 : 1N4148  
 D5 : 1N4148  
 D6 : 1N4148  
 D7 : 1N4148  
 D8 : 1N4007  
 D9 : 1N4007

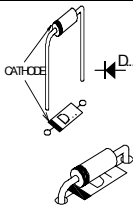
**3. Zener diode. Watch the polarity !**

- ZD1 : 2V4

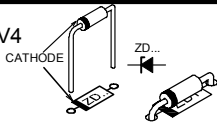
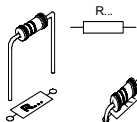
**4. Resistors**

- R1 : 47K (4 - 7 - 3 - B)  
 R2 : 47K (4 - 7 - 3 - B)  
 R3 : 47K (4 - 7 - 3 - B)  
 R4 : 47K (4 - 7 - 3 - B)  
 R5 : 220K (2 - 2 - 4 - B)  
 R6 : 470 (4 - 7 - 1 - B)  
 R7 : 470 (4 - 7 - 1 - B)  
 R8 : 10K (1 - 0 - 3 - B)  
 R9 : 10K (1 - 0 - 3 - B)  
 R10 : 1M (1 - 0 - 5 - B)

**5. IC sockets, Watch the position of the notch !**

- IC1 : 14p  
 IC2 : 14p

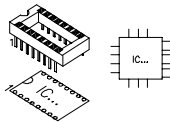
**6. Capacitor.**

- C1 : 100nF (104)

**7. Transistor.**

- T1 : BC547B

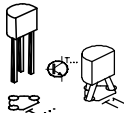
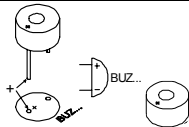
**8. Buzzer**

- Buz1

Remove the safety sticker from the buzzer, if any.

### 9. Electrolytic Capacitors. Watch the polarity !

- C2 : 22 $\mu$ F
- C3 : 22 $\mu$ F
- C4 : 22 $\mu$ F
- C5 : 22 $\mu$ F
- C6 : 22 $\mu$ F
- C7 : 470 $\mu$ F

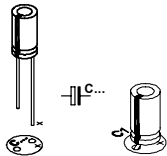

### 10. Screw connectors

- J1 : 2P
- J2 : 3P

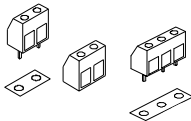

### 11. IC's. Check the position of the notch!

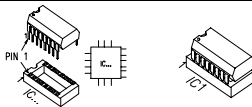

- IC1 : CD40106 or eq.
- IC2 : CD4070 or eq.

## 12. Use and connection

Mount the circuit underneath the dash board and make the following connections: (see Fig. 1.0)

- Connect the GND connection with the chassis or the battery (-) pole.
- Connect the L connection with the connection carrying voltage when the lights are turned on.
- Connect the C connection with the connection carrying voltage when the contact is switched ON.

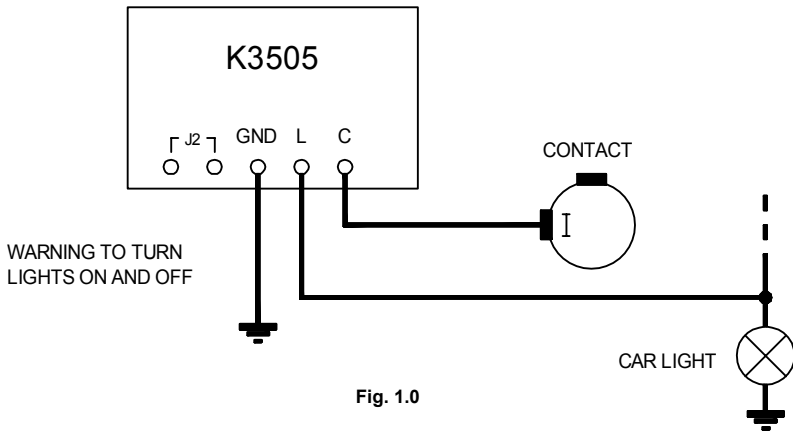

Fig. 1.0

If the alarm should only operate when the driver forgets to turn off the lights, a jumper should be inserted between the J2 connections.

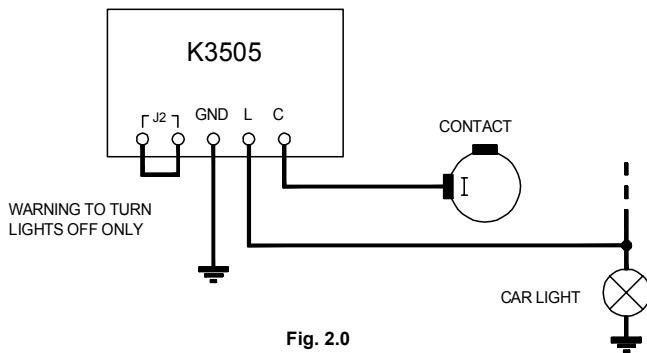
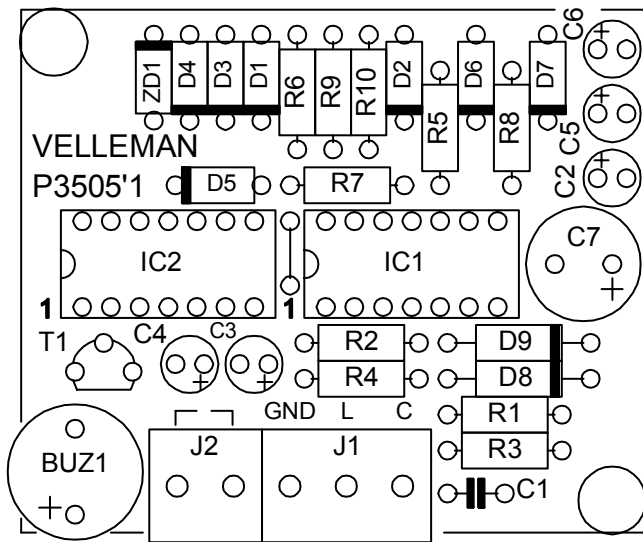
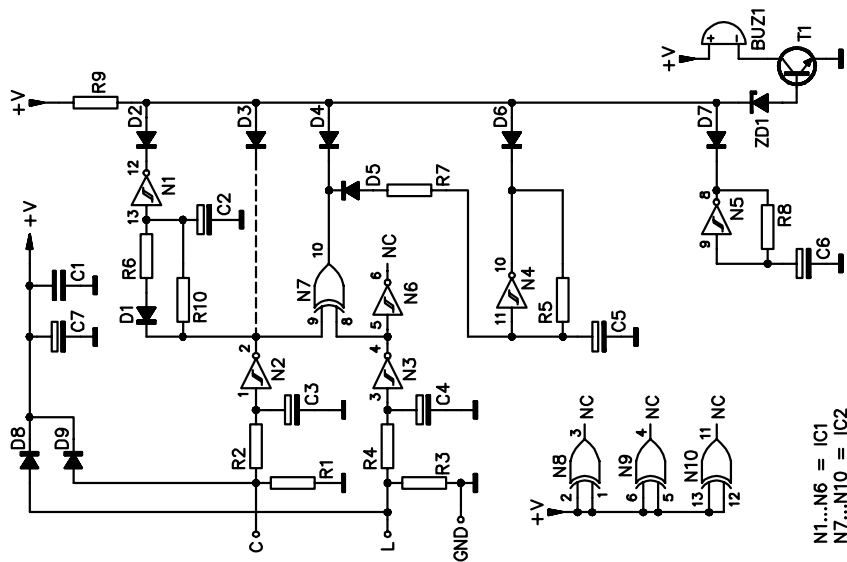

Fig. 2.0

## 13. PCB layout.



14. Diagram



**VELBUS**  
Velleman Home Automation System

**All appliances get intelligent, how about your home?  
see our website : [www.velbus.be](http://www.velbus.be)**

Modifications and typographical errors reserved  
 © Velleman Components nv.  
 H3505IP - 2004 - ED1

**VELLEMAN NV**  
**Legen Heirweg 33, 9890 Gavere**  
**Belgium - Europe**

